

CRAFTSMAN RAILING INSTALLATION GUIDE

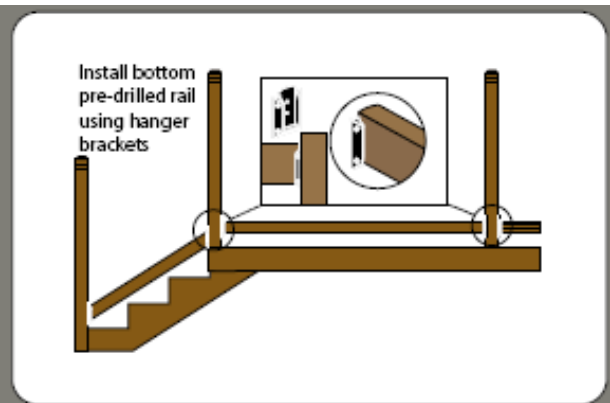

3 Install balusters

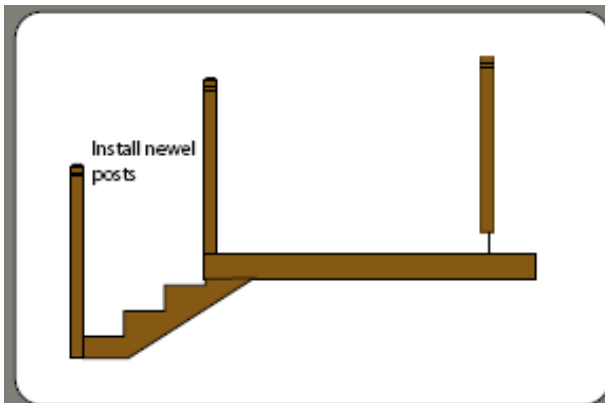
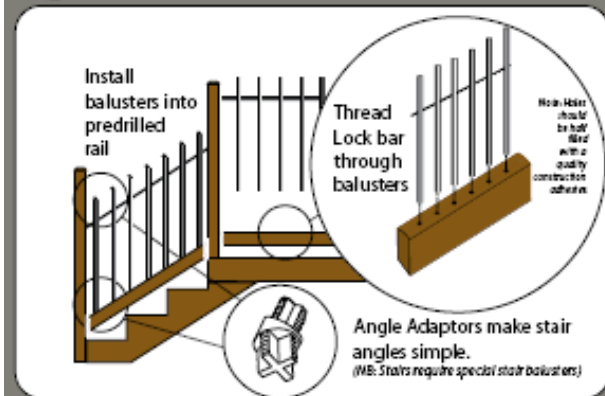

4 Install pre-drilled top rails

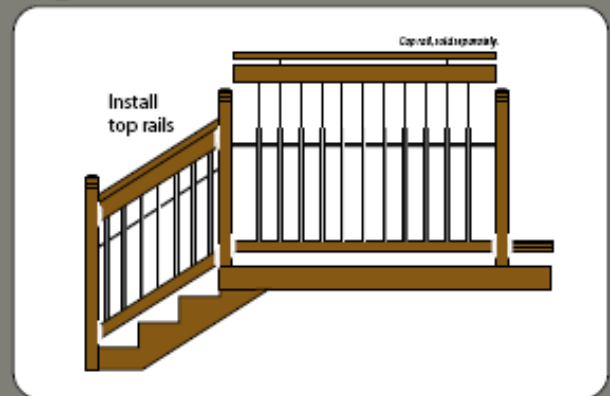

This document is a detailed step-by-step installation guide for the Craftsman rail system.

These instructions may not cover all scenarios that may arise. Before beginning your installation take time to read all instructions thoroughly. A fundamental understanding of carpentry and a basic knowledge of power tools is essential. Please call our technical support line for any assistance required. 1-800-667-8247

Building codes are constantly changing and they can vary by province, state, county, city, town, and/or borough. In order to learn which codes are being used and how they will affect you and your construction project, contact your local building inspection department, office of planning and zoning, and/or department of permits.

1

Step 1 Install Newel Posts

- A) Set posts to accommodate required rail lengths. See detail 1-5, 1-6 for post attachment methods. Considering your rail height, posts may be trimmed to a desirable post height.

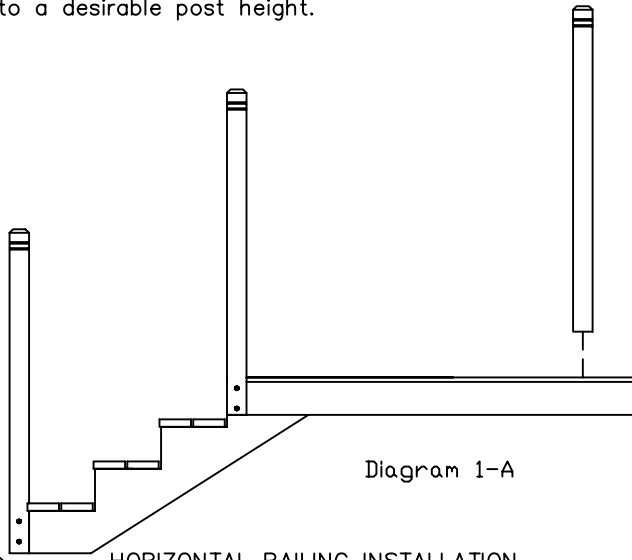

HORIZONTAL RAILING INSTALLATION

2

Step 2 Trimming the Pre-drilled Rails

- A) Measure the distance between posts.
 B) Mark the required length on the rails keeping pre-drilled holes centered between the marks.
 C) Subtract 1/8" (3mm) at each end for hanger brackets.
 D) For bottom rails, place brackets over ends of rail with pre-drilled holes and open end of bracket facing up. See diagram 2-E and detail 1-1. Fasten brackets to end of rail using 2-#8 x 1 3/4" (45mm) screws.
 E) For top rails, place brackets over ends of rail with pre-drilled holes facing down and open end of bracket facing up. Fasten brackets to end of rail using 2-#8 x 1 3/4" (45mm) screws.
 F) OPTIONAL METHOD for rail attachment without Rail Hanger Brackets follow steps A,B,D, and Detail 1-3.

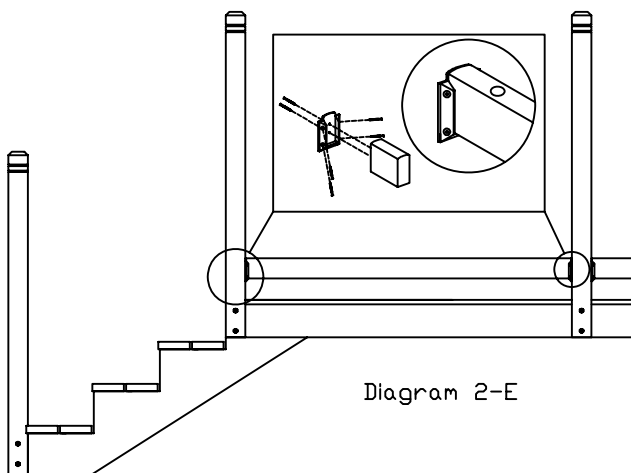

Diagram 2-E

3

Step 3 Installing the Bottom rails

- A) Use 3 13/16" (97mm) blocks or spacers under bottom rail to set rail to desired height.
 B) Attach bottom rail to post using 8-#8 x 1 3/4" (45mm) screws. See detail 1-1
 C) OPTIONAL METHOD for rail attachment without Rail Hanger Brackets Use 4-#10 x 3" (76mm) screws installed at a 45 degree angle to the post. See detail 1-3.

4

Step 4 Install Balusters

- A) Fill pre-drilled holes in bottom rail half way with a high quality construction adhesive that conforms to APA AFG-01.
 B) Insert balusters into pre-drilled rail (ensure balusters are fully inserted). See diagram 4-B
 C) Slide lockbar through balusters.

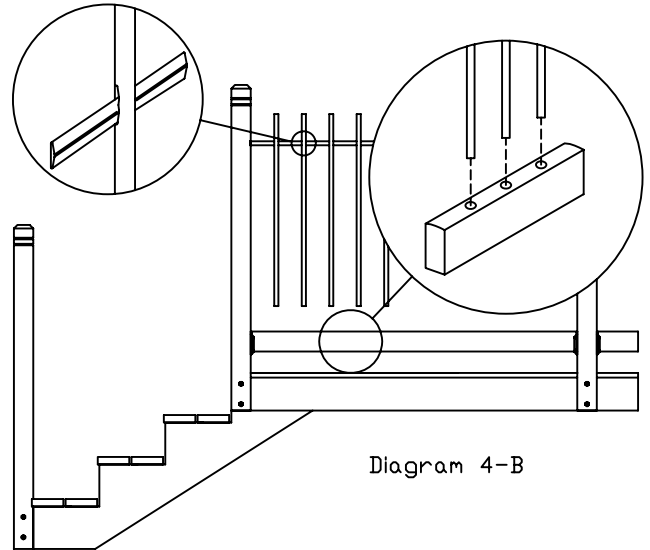

Diagram 4-B

5

Step 5 Installing The Top Rail

- A) Fill pre-drilled holes in top rail half way with a high quality construction adhesive that conforms to APA AFG-01.
 B) Place top rail over balusters and starting at one end of rail insert one baluster at a time into pre-drilled holes (ensure balusters are fully inserted). See detail 5-B
 C) Attach top rail to post using 8-#8 x 1 3/4" (45mm) screws. See Detail 1-1
 D) OPTIONAL METHOD for rail attachment without Rail Hanger Brackets. Use 4-#10 x 3" (76mm) screws installed at a 45 degree angle to the post. See Detail 1-3

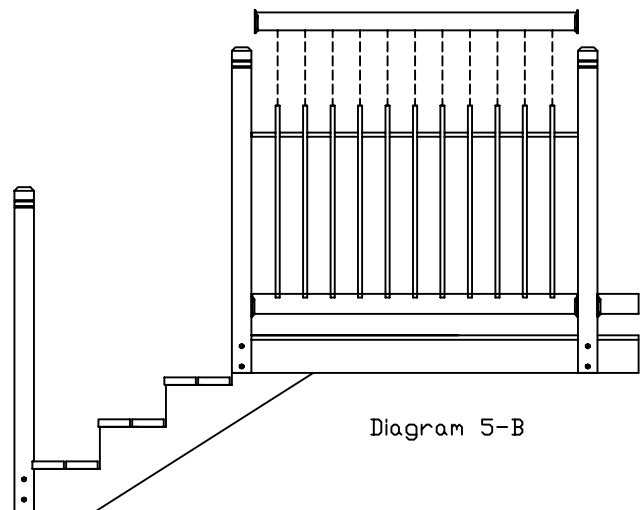

Diagram 5-B

6

STAIR INSTALLTION

Step 6 Trimming The Pre-drilled Rails

- A) Lay the bottom rail across the nosing of the stairs keeping the pre-drilled holes centered between the posts. Mark the points were it intersects the posts. See Detail 6-A
- B) Subtract 1/8" (3mm) at each end of rails for hanger brackets.
- C) Trim the bottom rail with a miter saw.
- D) Repeat this process for the top rail ensuring that the pre-drilled holes are facing downward.
- E) For bottom rails, place brackets over ends of rail with pre-drilled holes and open end of bracket facing up. See diagram 6-E and detail 1-1. Fasten brackets to end of rail using 2-#8 x 1 3/4" (45mm) screws.
- F) For top rails, place brackets over ends of rail with pre-drilled holes facing down and open end of bracket facing up. Fasten brackets to end of rail using 2-#8 x 1 3/4" (45mm) screws.
- G) OPTIONAL METHOD for rail attachment without Rail Hanger Brackets follow steps A,C,D, and Detail 1-3.

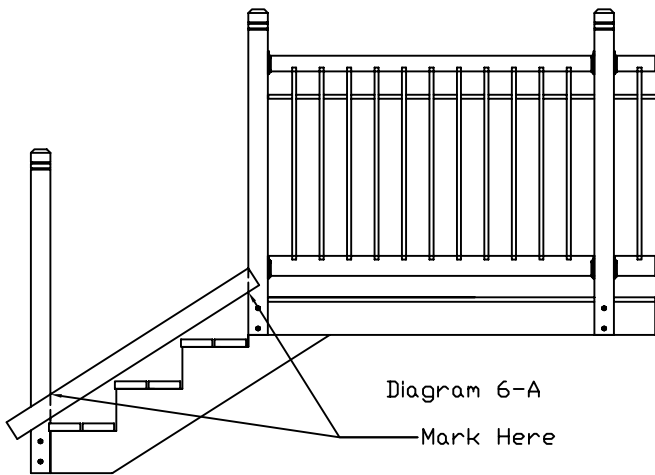

Diagram 6-A

7

Step 7 Installing the Bottom rail

- A) Place bottom rail between posts and raise rail approx. 3/4" (19mm) off the stair nosing See diagram 7-A
- B) Attach bottom rail to post using 8-#8 x 1 3/4" (45mm) screws. See Detail 1-1
- C) OPTIONAL METHOD for rail attachment without Rail Hanger Brackets. Use 4-#10 x 3" (76mm) screws installed at a 45 degree angle to the post. See Detail 1-3

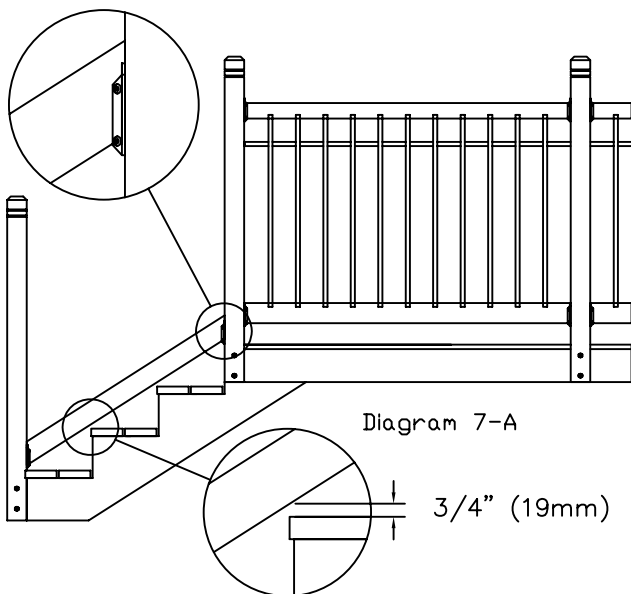

Diagram 7-A

3/4" (19mm)

8

Step 8 Install Stair Balusters

- A) Fill pre-drilled holes in bottom rail half way with a high quality constuction adhesive that conformes to APA AFG-01.
- B) Insert angle adapters into bottom of balusters.
- C) Push balusters into predrilled holes on bottom rail (ensure balusters are fully inserted). See diagram 8-C
- D) Slide lockbar through balusters.

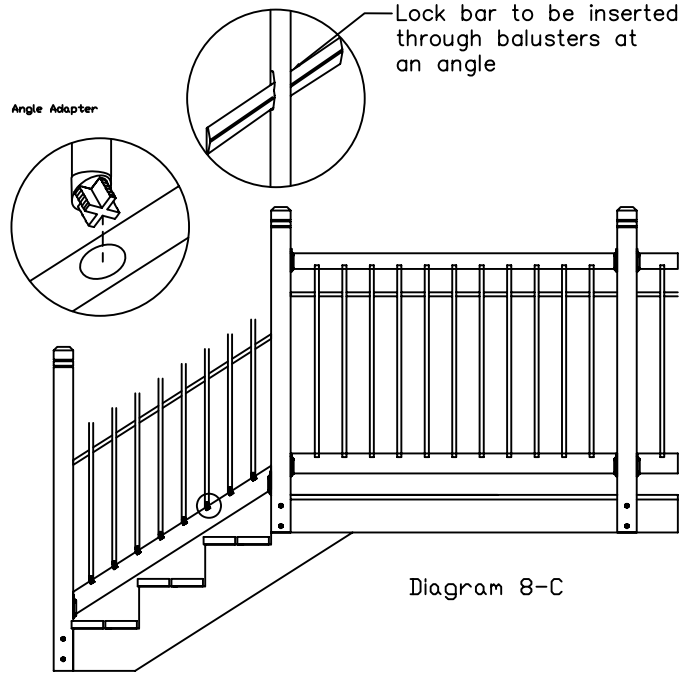

Diagram 8-C

9

Step 19 Installation of The Top Rail

- A) Fill pre-drilled holes in top rail half way with a high quality constuction adhesive that conformes to APA AFG-01.
- B) Insert angle adapters into the holes of the top rail ensuring the adapter is facing in the correct direction.
- C) Lower top rail over balusters and starting at one end of rail insert one adapter at a time into balusters (ensure balusters are fully inserted). See diagram 9-C
- D) Attach top rail to post using 8-#8 x 1 3/4" (45mm) screws.
- E) OPTIONAL METHOD for rail attachment without Rail Hanger Brackets see Detail 1-3. Use 4-#10 x 3" (76mm) screws installed at a 45 degree angle to the post.

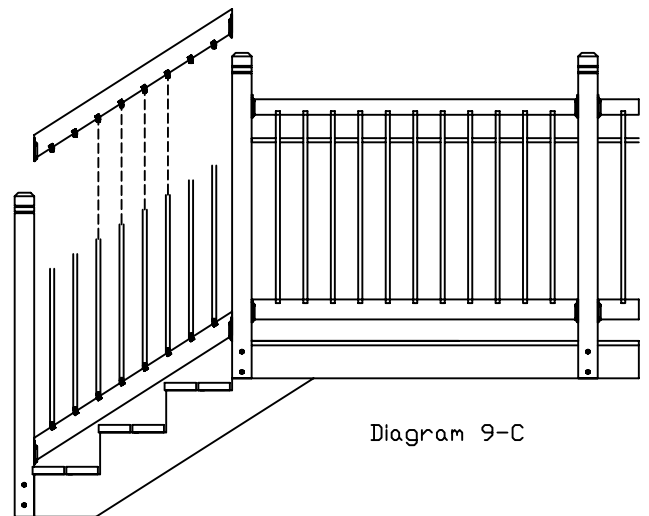
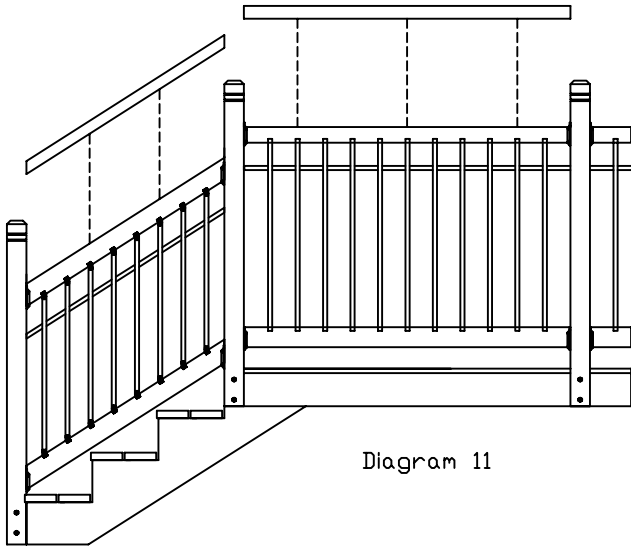

Diagram 9-C

10

Step 6 Installing The Cap Rail

- A) Measure the distance between the posts.
- B) Mark the required length on the cap rail and trim with a miter saw.
- C) Apply exterior type II glue to the top rail. Cap rail is fitted on top and nailed, 2 1/2" (63mm) galvanized nails @ 12" (600mm). See detail 1-3
Fasten the cap rail to the post using 2-#8 x 2" (50mm) screws installed at a 45 degree angle. See detail 1-1 and 1-3.



11

Step 11 Construction And Finishing Tips

- A) Installation of screws in rails should be pre-drilled to prevent splitting.
- B) If ACQ treated wood has been trimmed, it is necessary to re-finish the cut end. Check with your local paint department for the appropriate finish to use.
- C) Finish with exterior paint or stain before assembly.

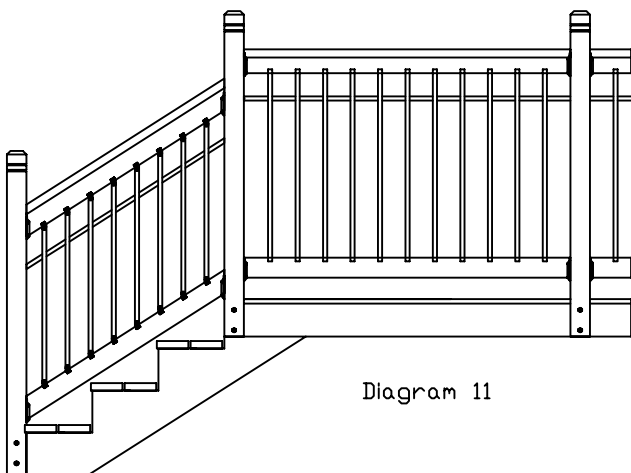

Detail 1-1

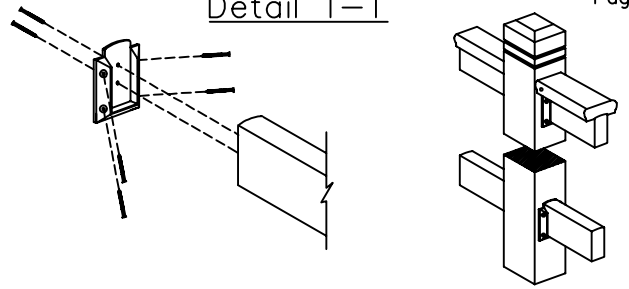

Axonometric

Post 2-#8 x 2" (50mm) Stainless Steel Screws Per Connection

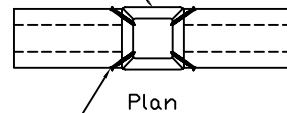

2-#8 x 2" (50mm) Stainless Steel Screws Per Connection

6-#8 x 1 3/4" (44mm) Stainless Steel Screws Per Connection

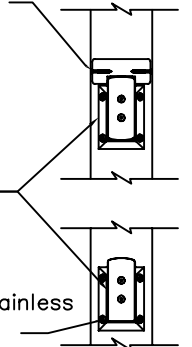

Detail 1-1

Exterior Connection:

Cap Rail Glued and Nailed 2 1/2" (63mm) @ 12" (600mm) to Top Rail, Skew Screwed to Post-2" (50mm) screws
Top/ Bottom Rail Skew Screwed to Post-1 3/4" (45mm) screws.

- 1) Nails and screws shall not cause splitting of wood elements.
- 2) Fasteners shall be resistant to corrosion.
- 3) Glue Exterior Type II.

Detail 1-3

2 1/2" (63mm) Galvanized Nails @ 12" (600mm)

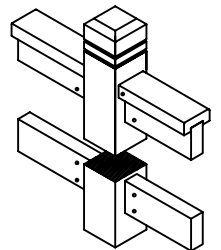
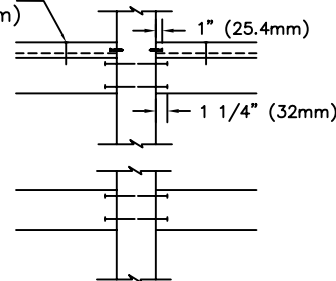

4-#10 x 3" (76mm) Stainless Steel Screws Per Connection

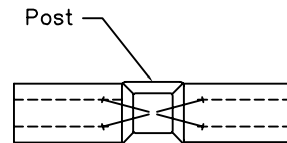

Plan

Rails

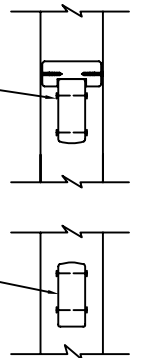

Detail 1-3

Exterior Connection:

Cap Rail Glued and Nailed 2 1/2" (63mm) @ 12" (600mm) to Top Rail, Skew Screwed to Post-2" (50mm) screws
Top/ Bottom Rail Skew Screwed to Post-3" (76mm) screws.

- 1) Nails and screws shall not cause splitting of wood elements.
- 2) Fasteners shall be resistant to corrosion.
- 3) Glue Exterior Type II.

Detail 1-5 Exterior Connection: Post screwed to rim joist

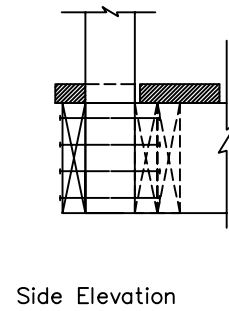
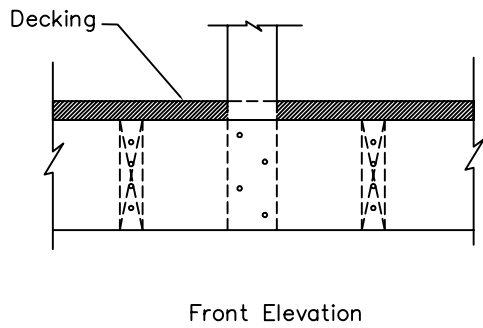
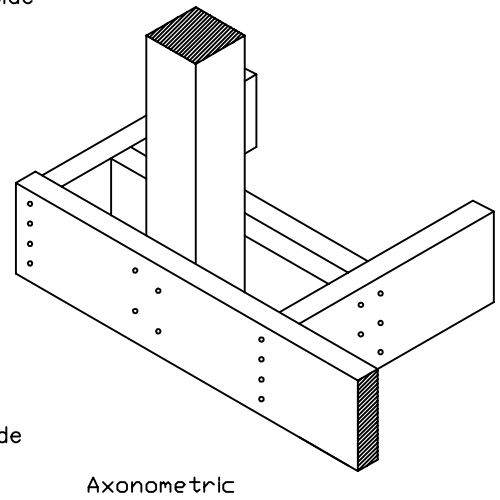
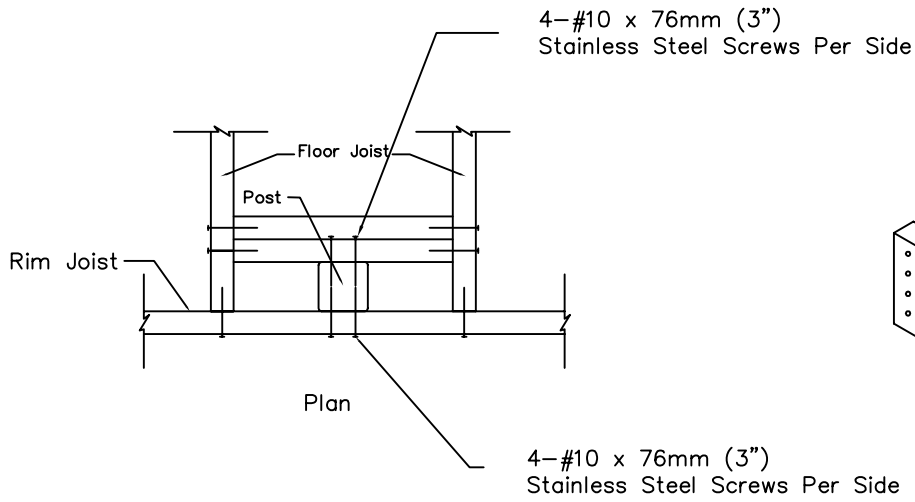

Detail 1-5

Exterior Connection: Post Nailed To Rim Joist

- 1) Decking is omitted from plan view and the axonometric view for clarity.
- 2) Fasteners shall be resistant to corrosion.

RAILSIMPLE™

RAILING SYSTEMS·COMPONENTS·ACCESSORIES

For Technical support
please call

1-800-667-8247

Instructions are also available on
our website www.railsimple.com

Tool List

Hammer	Ratchet Wrench	Tape Measure
Wood Chisel	Miter saw	Level
Clamps	Hand Drill	
Stainless Screws #8 x 2" (50mm)	Drill Bit Size $\frac{9}{64}$ " (3.5mm)	
Stainless Screws # 10 x 3" (76mm)	Drill Bit Size $\frac{11}{64}$ " (4mm)	
Galvanized Nails 2 ½" (63mm)		
Carpenters Glue (exterior type II)		
Construction Adhesive (conformes to APA AFG-01)		